



Rotary Air Pumps

PAR Series - 10,000 PSI Rated



Related Product: Gauges

Reduce the risk of overloading your product by using a gauge. A variety of graduations and types to suit any need.

pg 65



Related Product: Hoses

We offer a variety of hoses, fittings, lengths and materials.

pg 67



PARM4003

PARD1701

PARD1703

PAR Series

PARD1701

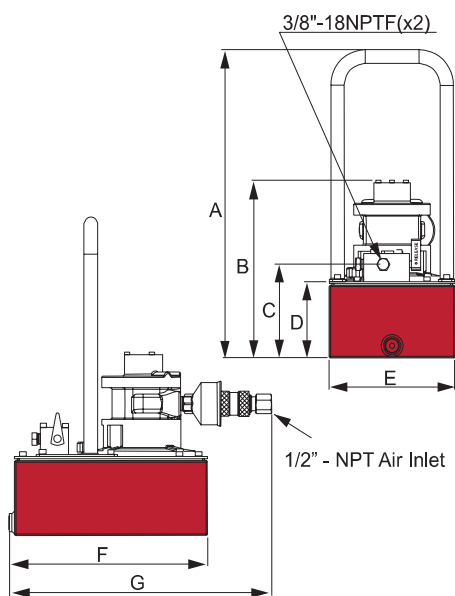

PARD1703 and PAR4003

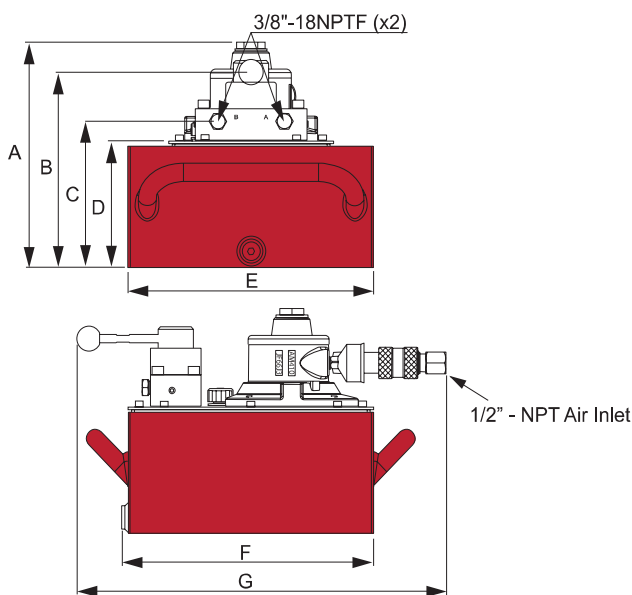

Used with Cylinder	Motor Size (hp)	Usable Oil Capacity (L)	Model Number	Pressure Rating (BAR)	Pressure Rating		Oil Output Flow Rate		Valve Type	Valve Function	Air Pressure Range (BAR)
					1 st Stage (BAR)	2 nd Stage (BAR)	1 st Stage (L/min)	2 nd Stage (L/min)			
Single Acting	1.7	3.8	PARD1701	700	48.30	700	5.13	0.36	Dump	Advance/Return	4.14~5.52
	1.7	11.4	PARD1703	700	48.30	700	5.13	0.36	Dump	Advance/Return	4.14~5.52
	1.7	11.4	PAR1703	700	48.30	700	6.83	0.36	Manual PW3	Advance/Hold/Return	4.14~5.52
	4	11.4	PAR4003	700	48.30	700	7.62	1.15	Dump	Advance/Return	4.14~0.69
	4	11.4	PAR4003	700	48.30	700	8.39	1.15	Manual PW3	Advance/Hold/Return	4.14~0.69
Double Acting	1.7	11.4	PARM1703	700	48.30	700	6.83	0.36	Manual PW4	Advance/Hold/Return	4.14~5.52
	4	11.4	PARM4003	700	48.30	700	8.39	1.15	Manual PW4	Advance/Hold/Return	4.14~0.69

Model Number	Air Consumption (L/min)	Max Sound Level (dBA)	Dimensions (mm)							Weight (kg)
			A	B	C	D	E	F	G	
PARD1701	1245.94	93	485	239	147	120	205	313	404	19.1
PARD1703	1245.94	93	-	304	212	185	305	313	456	24.5
PAR1703	1245.94	93	303	267	209	185	305	313	459	24.9
PARD4003	2690.10	100	-	344	212	185	305	313	467	29.9
PAR4003	2690.10	100	344	267	209	185	305	313	470	30.4
PARM1703	1245.94	93	303	267	209	185	305	313	459	24.9

Universal Motor Pumps

PU Series - Light-Weight Pumps



PU20M4N01B

- Portable, light weight and compact design
- Universal Motor, starts under full load and is available in either 120VAC 50/60 HZ or 240VAC 50/60HZ
- 3mt 24 VAC pendant control for safety
- Weighs only 17 kg. with oil
- External pressure adjustment is available
- Designed for intermittent duty operation
- Gauge port on control valve

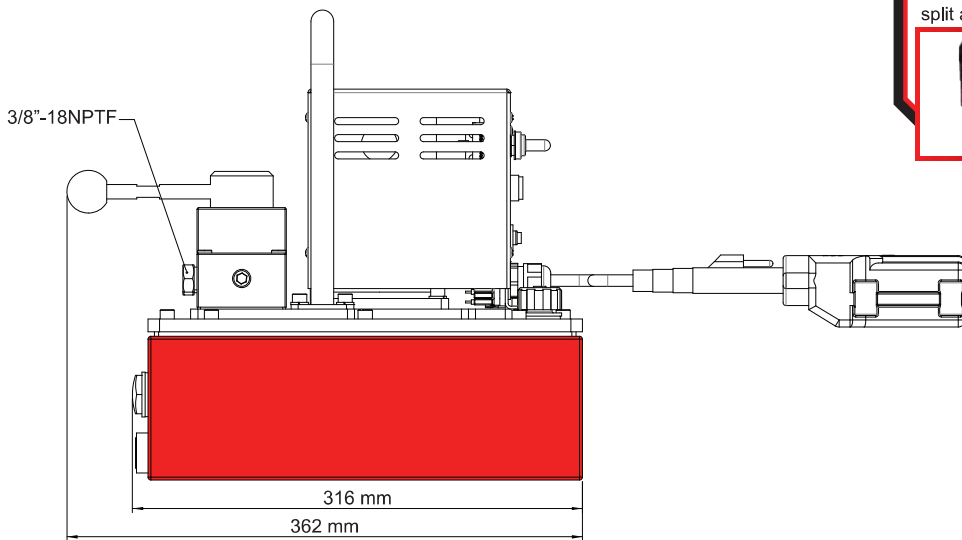
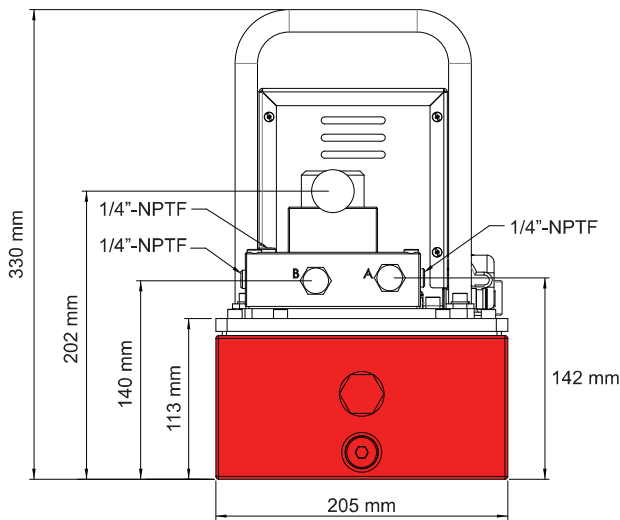

Hydraulic Gear Pullers

5, 10, 15, 25 & 50 Ton Hydraulic Gear Pullers have a safety cage design to help keep the jaws tight to the gear and prevent slippage that can cause injury. Pair these with BVA's PU20M3N01B Lightweight e-pump for portability.



pg 88

Flange Spreaders

BVA's Pin Type Flange Spreaders are available in both 5 & 10 Ton models and well suited for most environments. For portability and speed the PU20M4N01B would be an ideal choice.



pg 91

Hydraulic Nut Splitters

Available in 3 models, each nut splitter can split a wide range of nut sizes thereby reducing the number of splitters needed. The BVA PU20DMP01B dump style pump functions well with these splitters



pg 92

Valve Function	Flow Rate				Motor Size	Voltage 50/60 Hz		Weight (kg)	Length (mm)	Width (mm)	Height (mm)
	1st Stage		2nd Stage			120 VAC	240 VAC				
	L/min	BAR	L/min	BAR		Model #	Model #				
3W/3P Advance/Hold Return	2.18	13.80	0.46	700	1.0 Hp	PU20M3N01B	PU20M3N01C	16.8	362	205	300
4W/3P Advance/Hold/Return	2.18	13.80	0.46	700	1.0 Hp	PU20M4N01B	PU20M4N01C	16.8	362	205	300